

CF-2880E

MAGNETIC EXERCISE BIKE

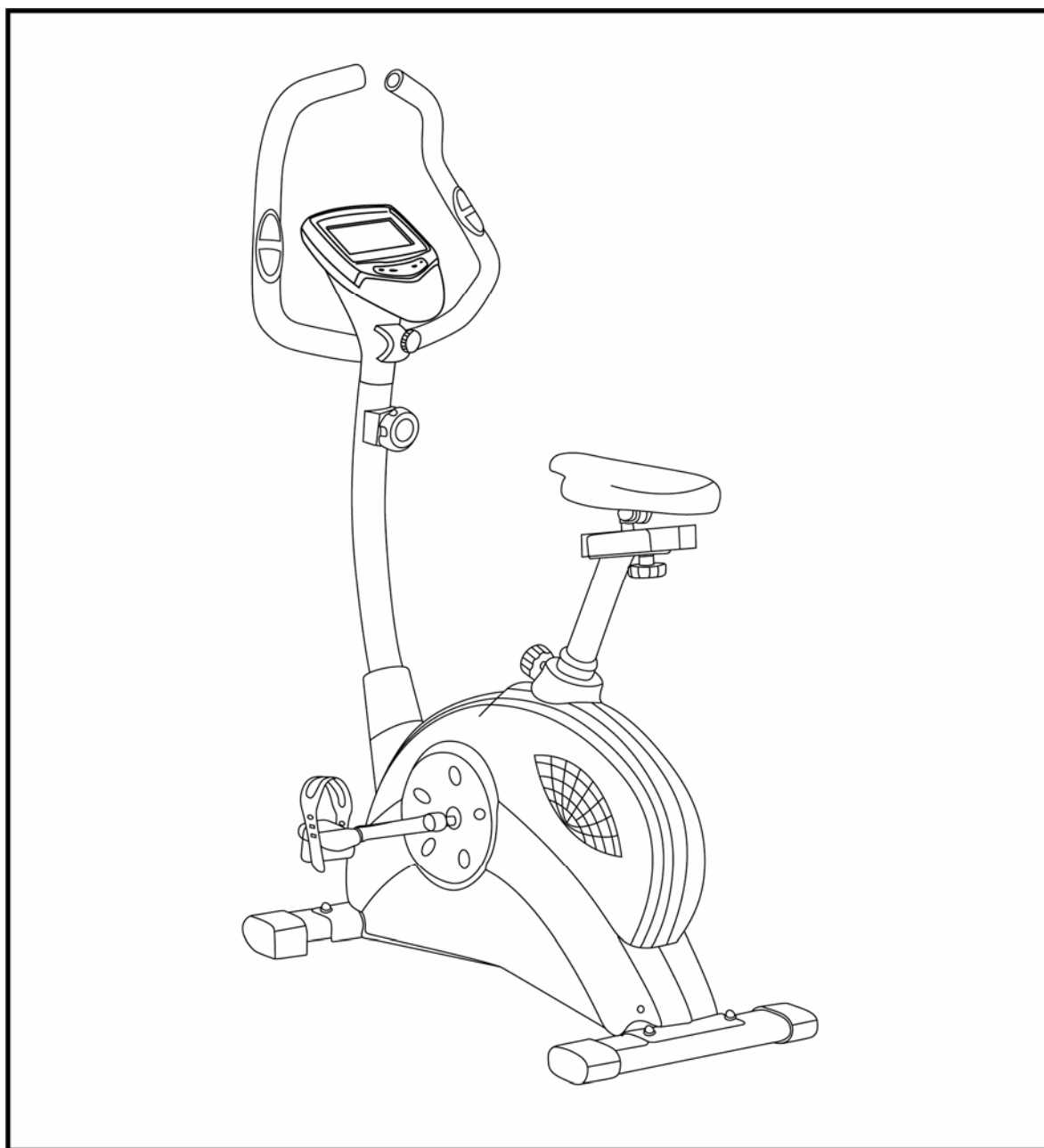

Important Safety Information

Please keep this manual in a safe place for reference.

1. It is important to read this entire manual before assembling and using the equipment. Safe and efficient use can only be achieved if the equipment is assembled, maintained and used properly. It is your responsibility to ensure that all users of the equipment are informed of all warnings and precautions.
2. Before starting any exercise program you should consult your doctor to determine if you have any physical or health conditions that could create a risk to your health and safety, or prevent you from using the equipment properly. Your doctor's advice is essential if you are taking medication that affects your heart rate, blood pressure or cholesterol level.
3. Be aware of your body's signals. Incorrect or excessive exercise can damage your health. Stop exercising if you experience any of the following symptoms: Pain, tightness in your chest, irregular heartbeat, extreme shortness of breath, feeling light headed, dizzy or nauseous. If you do experience any of these conditions you should consult your doctor before continuing with your exercise program.
4. Keep children and pets away from the equipment. The equipment is designed for adult use only.
5. Use the equipment on a solid, flat level surface with a protective cover for your floor or carpet. For safety, the equipment should have at least 0.5 metre of free space all around it.
6. Before using the equipment, check the nuts and bolts are securely tightened. Some parts like pedals, etc., it's easy to be wared away.
7. The safety level of the equipment can only be maintained if it is regularly examined for damage and/or wear and tear.
8. Always use the equipment as indicated. If you find any defective components whilst assembling or checking the equipment, or if you hear any unusual noise coming from the equipment during use, stop. Do not use the equipment until the problem has been rectified.
9. Wear suitable clothing whilst using the equipment. Avoid wearing loose clothing which may get caught in the equipment or that may restrict or prevent movement.
10. The equipment has been tested and certified to EN957 under class H.C. Suitable for domestic, home use only. Maximum weight of user, 100kg. Breaking is speed independent.
11. The equipment is not suitable for therapeutic use.
12. Care must be taken when lifting or moving the equipment so as not to injure your back. Always use proper lifting techniques and/or use assistance.
13. Technical assistance service: contact the establishment where you purchased the product, showing the purchase receipt.

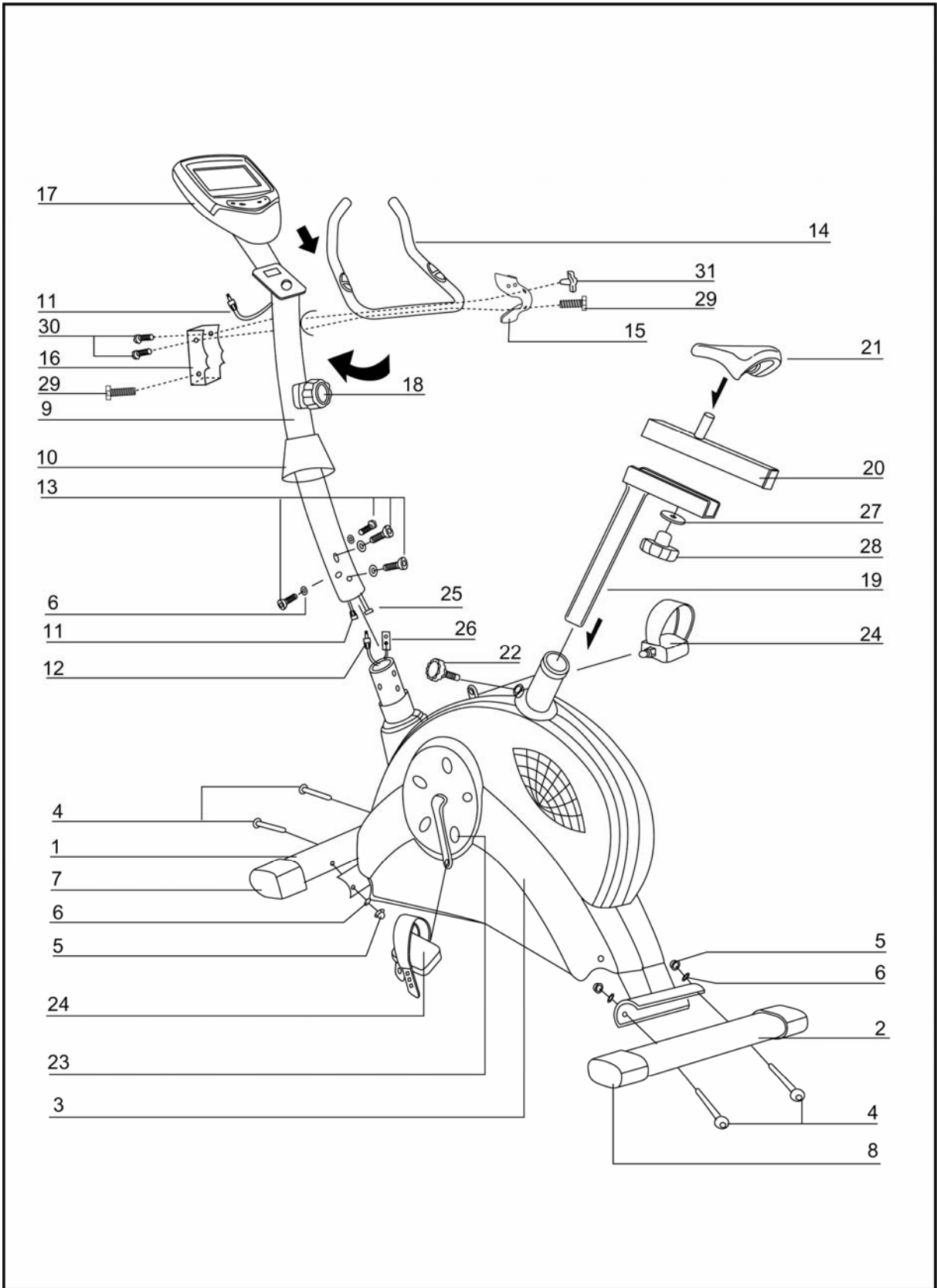



Allen key Bolt
(M8x16mmL)

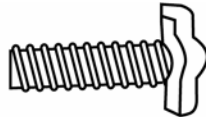

Adjusting knob
for handle bar



Key Head Bolt
(M8x70mmL)



Allen key Bolt
(M4x20mmL)



Allen key Bolt
(M5x10mmL)

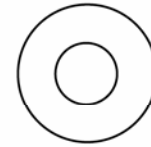

Washer (A)

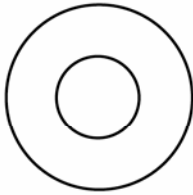

Washer (C)

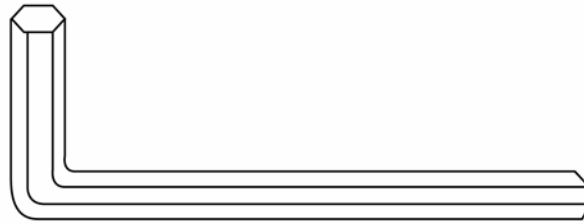

Allen Wrench



Washer (B)

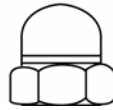

Nylock Nut
(M8)



Domed Nut
(M8)

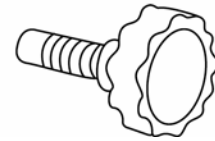

Adjusting Knob

PART LIST

No.	Description	Q'ty	No.	Description	Q'ty
1	Front Stabilizer	1	16	Plastic protection below computer	2
2	Rear Stabilizer	1	17	Computer	1
3	Main Frame	1	18	Tension Knob	1
4	Key Head Bolt(M8x70mmL)	4	19	Seat Post	1
5	Domed Nut	4	20	Adjustment	1
6	Washer (A)	8	21	Seat	1
7	Front End Cap	4	22	Adjusting Knob	1
8	Rear End Cap	4	23	Crank Assemble	1
9	Front Post	1	24	Pedal (L & R)	2
10	Plastic Protection	1	25	Tension Cable	1
11	Computer Extension Cable	1	26	Tension Hook	1
12	Sensor Wire	1	27	Washer (C)	1
13	Allen Key Bolt(M8x16mmL)	4	28	Adjustment knob	1
14	Handle bar	1	29	Allen Key Bolt(M5x10mmL)	2
15	Plastic protection below computer	1	30	Allen Key Bolt(M4x20mmL)	2
			31	Adjusting knob for handle bar	1

ASSEMBLY INSTRUCTION

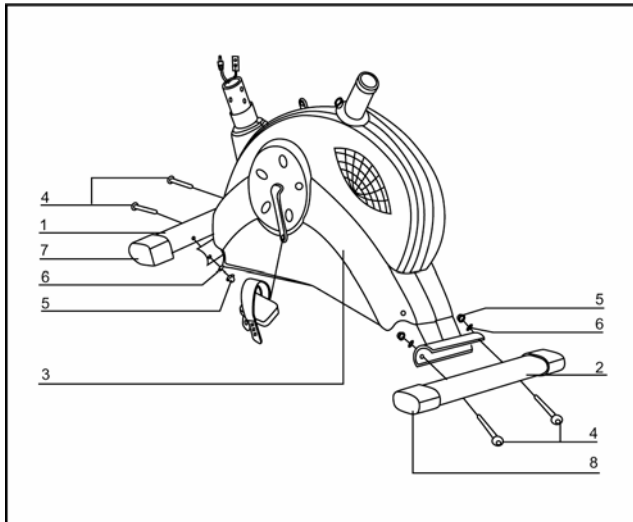

STEP 1

Attach the two stabilizers (1) & (2) to the main frame (3) using four sets of domed nuts (5), washers (6) and M8 x 70 key head bolts (4).

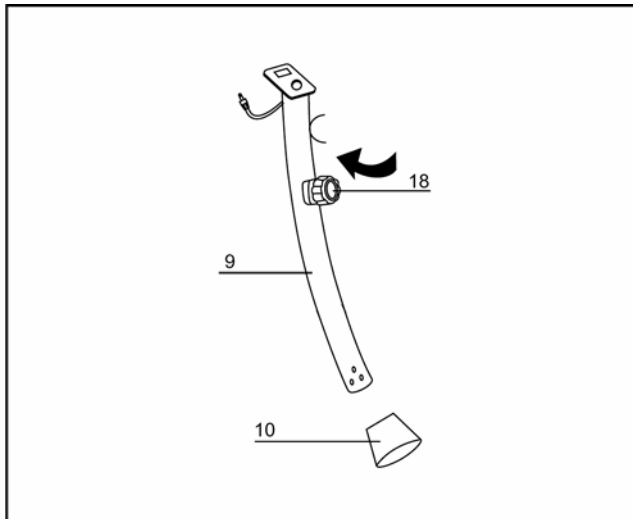

STEP 2

Take the front post into the plastic protection (10) and move the plastic protection (10) up.

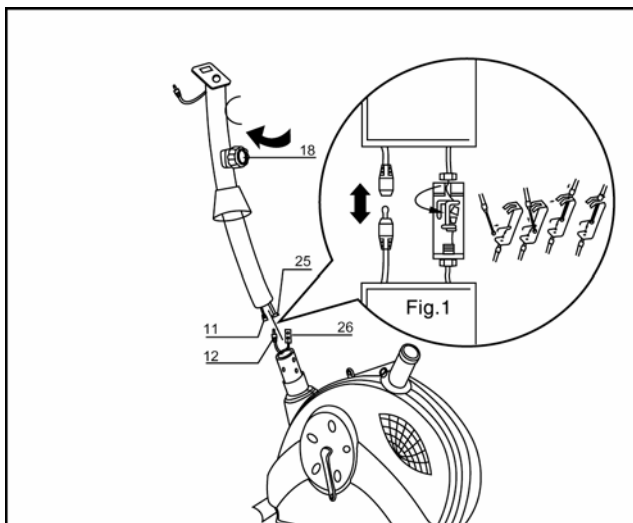

STEP 3

Take the front post and join the upper computer wire (11) with lower computer wire (12). Then connect the bottom of the Upper Tension Cable (25) to the lower Tension Hook (26) (show in Fig.1)

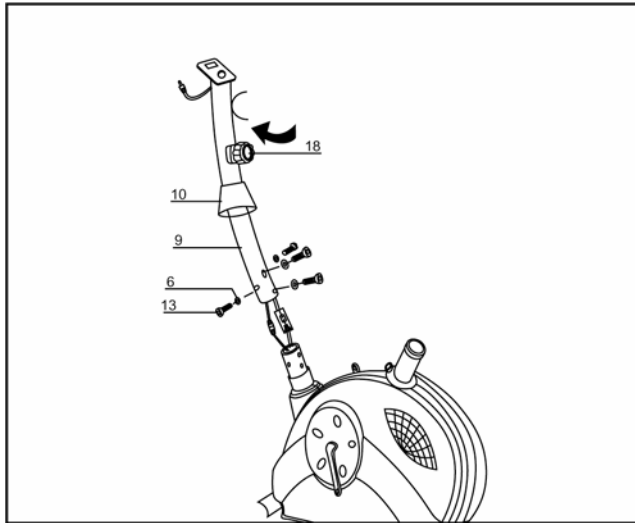

STEP 4

Slide the front post (9) into the front post housing, and then fix with four sets of M8 x 16mm bolts (13) and washers (6). Making sure you do not trap any of the wires, and slide the plastic protection (10) into the front post housing.

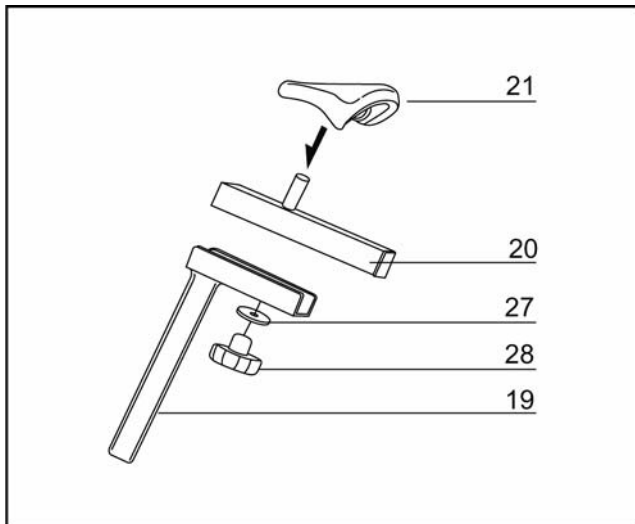

STEP 5

Tap the Seat Post (19) into the end of the fabrication

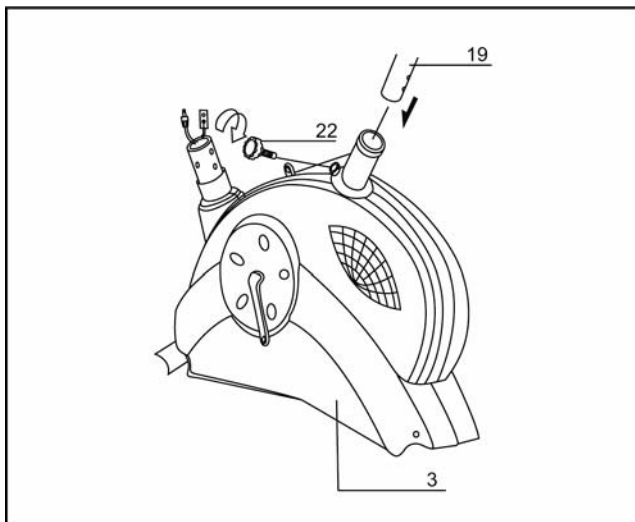

STEP 6

Insert the seat post (19) into the frame (3) and line up the holes. Secure the seat in position with the Adjusting knob (22). The correct height for the seat can be adjusted after the bike is fully assembled.

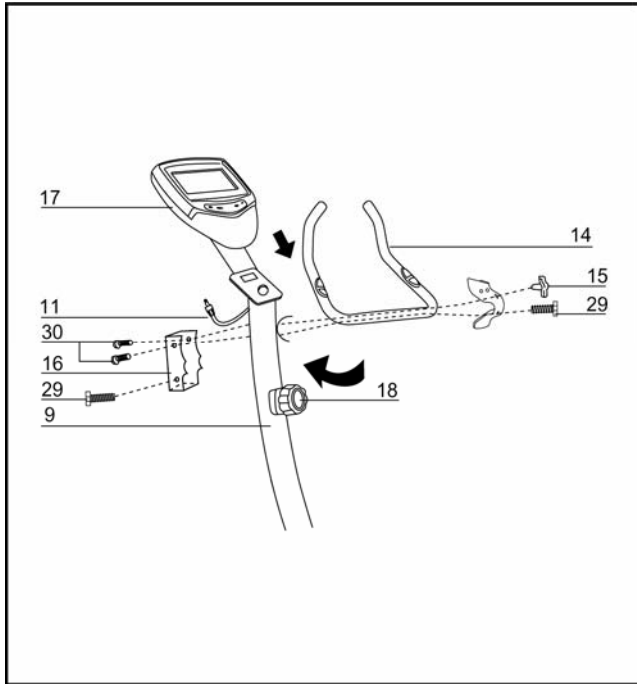

STEP 7

Attach the handle bar (14) to the Front post (9) as picture Slide the computer (17) to computer holder.

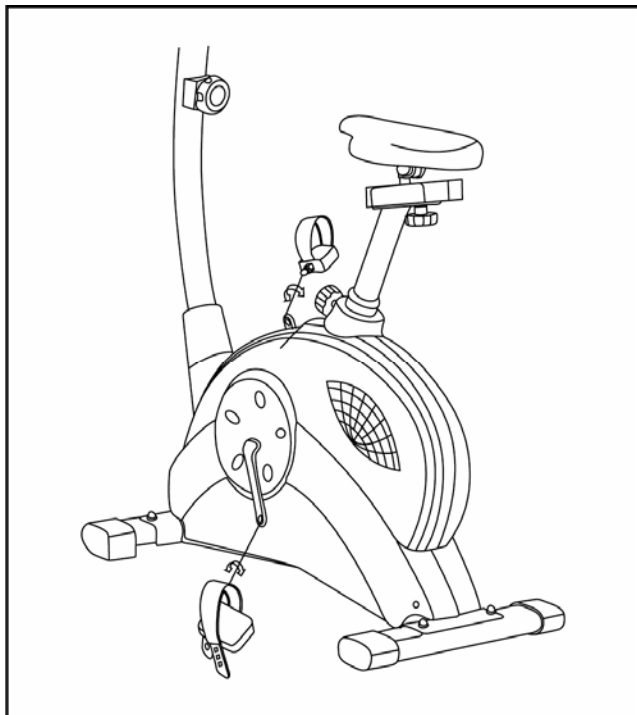

STEP 8

The pedals (24) are marked "L" and "R"-Left and Right. Connect them to their appropriate crank arms. The right crank arm is on the right hand side of the cycle as you sit on it. Note that the Right pedal should be threaded on clockwise and the Left pedal anti-clockwise.

EXERCISE INSTRUCTIONS

Using your EXERCISE CYCLE will provide you with several benefits, it will improve your physical fitness, tone muscle and in conjunction with calorie controlled diet help you lose weight.

1. The Warm Up Phase

This stage helps get the blood flowing around the body and the muscles working properly. It will also reduce the risk of cramp and muscle injury. It is advisable to do a few stretching exercises as shown below. Each stretch should be held for approximately 30 seconds, do not force or jerk your muscles into a stretch - if it hurts, STOP.

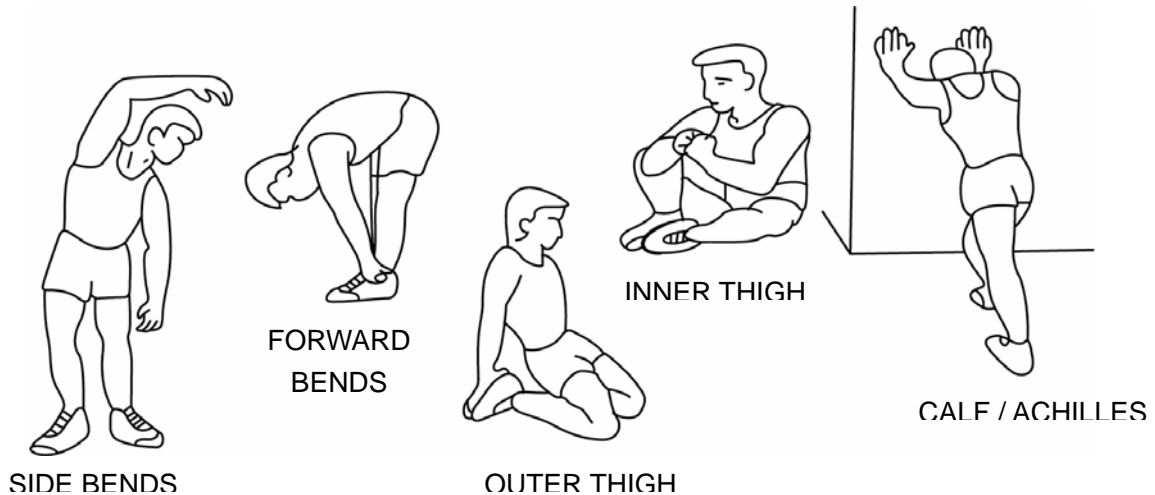

2. The Exercise Phase

This is the stage where you put the effort in. After regular use, the muscles in your legs will become more flexible. Work to your own pace but it is very important to maintain a steady tempo throughout. The rate of work should be sufficient to raise your heart beat into the target zone shown on the graph below.

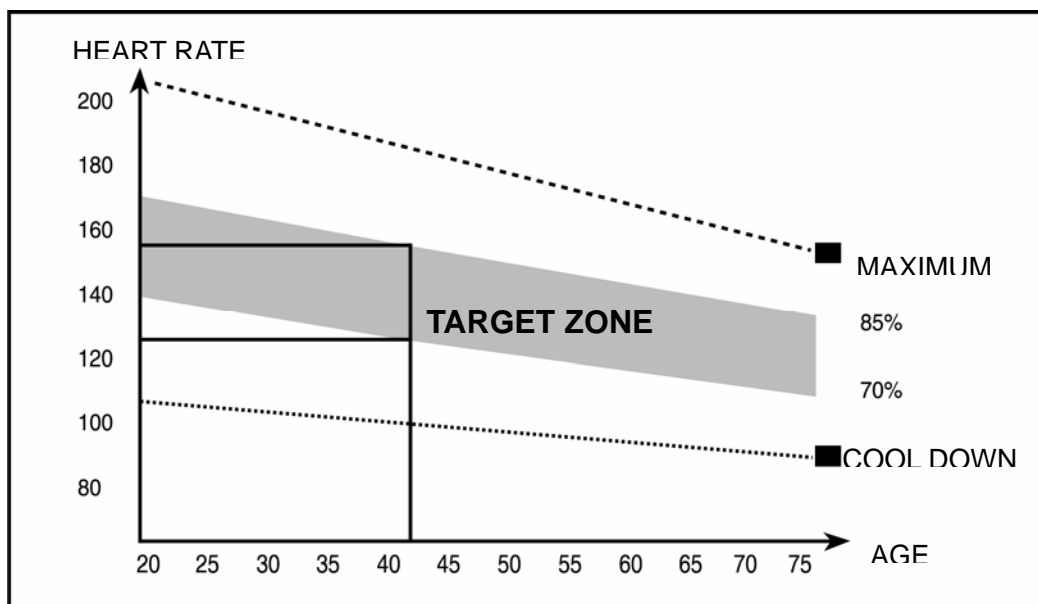

This stage should last for a minimum of 12 minutes though most people start at about 15-20 minutes.

3. The Cool Down Phase

This stage is to let your Cardio-vascular System and muscles wind down. This is a repeat of the warm up exercise e.g. reduce your tempo, continue for approximately 5 minutes. The stretching exercises should now be repeated, again remembering not to force or jerk your muscles into the stretch. As you get fitter you may need to train longer and harder. It is advisable to train at least three times a week, and if possible space your workouts evenly throughout the week.

4. Fault Finder

1. If you do not receive numbers appearing on your computer, please ensure all connections are correct.

MUSCLE TONING

To tone muscle while on your EXERCISE CYCLE you will need to have the resistance set quite high. This will put more strain on your leg muscles and may mean you cannot train for as long as you would like. If you are also trying to improve your fitness you need to alter your training program. You should train as normal during the warm up and cool down phases, but towards the end of the exercise phase you should increase resistance making your legs work harder. You will have to reduce your speed to keep your heart rate in the target zone.

WEIGHT LOSS

The important factor here is the amount of effort you put in. The harder and longer you work the more calories you will burn. Effectively this is the same as if you were training to improve your fitness, the difference is the goal.

USE

The seat height can be adjusted by removing the adjustment knob and raising or lowering the seat. There are 7 holes in the seat post allowing for a range of heights. Once the correct height has been chosen, refit the adjustment knob and tighten. The tension control knob allows you to alter the resistance of the pedals. A high resistance makes it more difficult to pedal, a low resistance makes it easier. For the best results set the tension while the bike is in use.

SPECIFICATIONS:

TIME(TMR).....00:00-99:59 CALORIES(CAL).....0-9999KCAL
SPEED(SPD).....0.0-99.9KM/H PULSE.....40-240BPM
DISTANCE(DST).....0.00-999.9KM

KEY FUNCTIONS:

MODE: This key lets you to select and lock on to a particular function you want.

PAUSE: Press to start or stop the operation of functions.

SET: The key allows you to choose a target value for TIME, DISTANCE, CALORIES & PULSE.

RESET: Reset the value to zero by pressing the key.

OPERATION PROCEDURES:

1. AUTO ON/OFF

The system turns on when any key is pressed or when it sensor an input from the speed sensor.

The processor turns off automatically when the speed has no signal input or no key is pressed for approximately 4 minutes.

2. RESET:

The unit can be reset by either changing battery or pressing the RESET key for 3 seconds.

3. HOW TO PRESET TIME, DISTANCE, PULSE & CALORIES:

Press the MODE KEY until the function brand which is going to be preset is flashing.

Press the MODE key once the function brand stop flashing.

Next, Choose the value you want to exercise by the SET key.

When the speed sensor has any signal input, The monitor will begin to count down.

It will beep for 10 seconds to indicate the completion of workout which is present, press any key to stop beeping.

If data is not preset, Any function date will count up.

TIME: The time of exercise will be displayed by pressing MODE. Key until brand TMR appear.

SPEED: Current speed will be shown by pressing MODE key until brand DST appear.

DISTANCE: The distance of each workout will be displayed by pressing MODE key until brand DST appear.

PULSE: User's current heart rate is displayed in beats per minute(BPM) by pressing MODE key until brand PULSE appear, Place the palms of your hands on both of the contact pads and wait for 30 seconds for the most accurate reading.

CALORIES: The calories burned will be displayed by pressing MODE key until brand CAL appear.

SCAN: Automatic display of the following functions in the order shown:

TIME-SPEED-DISTANCE-PULSE-CALORIES(repeat).

4. BATTERY

This monitor users two "AA" or AG 13 batteries. You can replace the batteries at the back of the unit.